

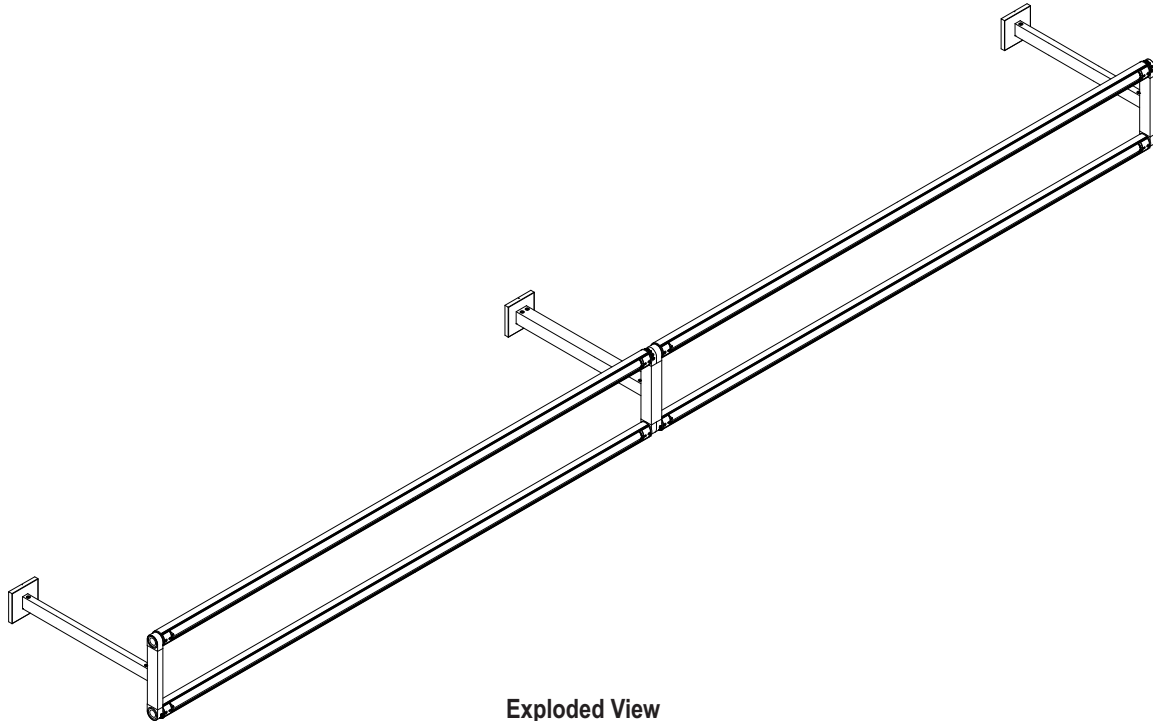

Please read instructions in their entirety before proceeding with any part of the installation. This luminaire must be installed in accordance with the National Electric Code and local regulations. Use of ballasts or other components not supplied by Vode Lighting voids warranty. To prevent electric shock, turn off electricity at the fuse box before proceeding. Do not install this product in wet locations. UL listed for dry and damp locations only. Retain instructions for future reference. Technical Support: 707-996-9898



Exploded View

Components for Vode MLR System • 2" Canopy • 1 lamp • Double Rail • Continuous System with 24", 36", 48" or 60" Rails

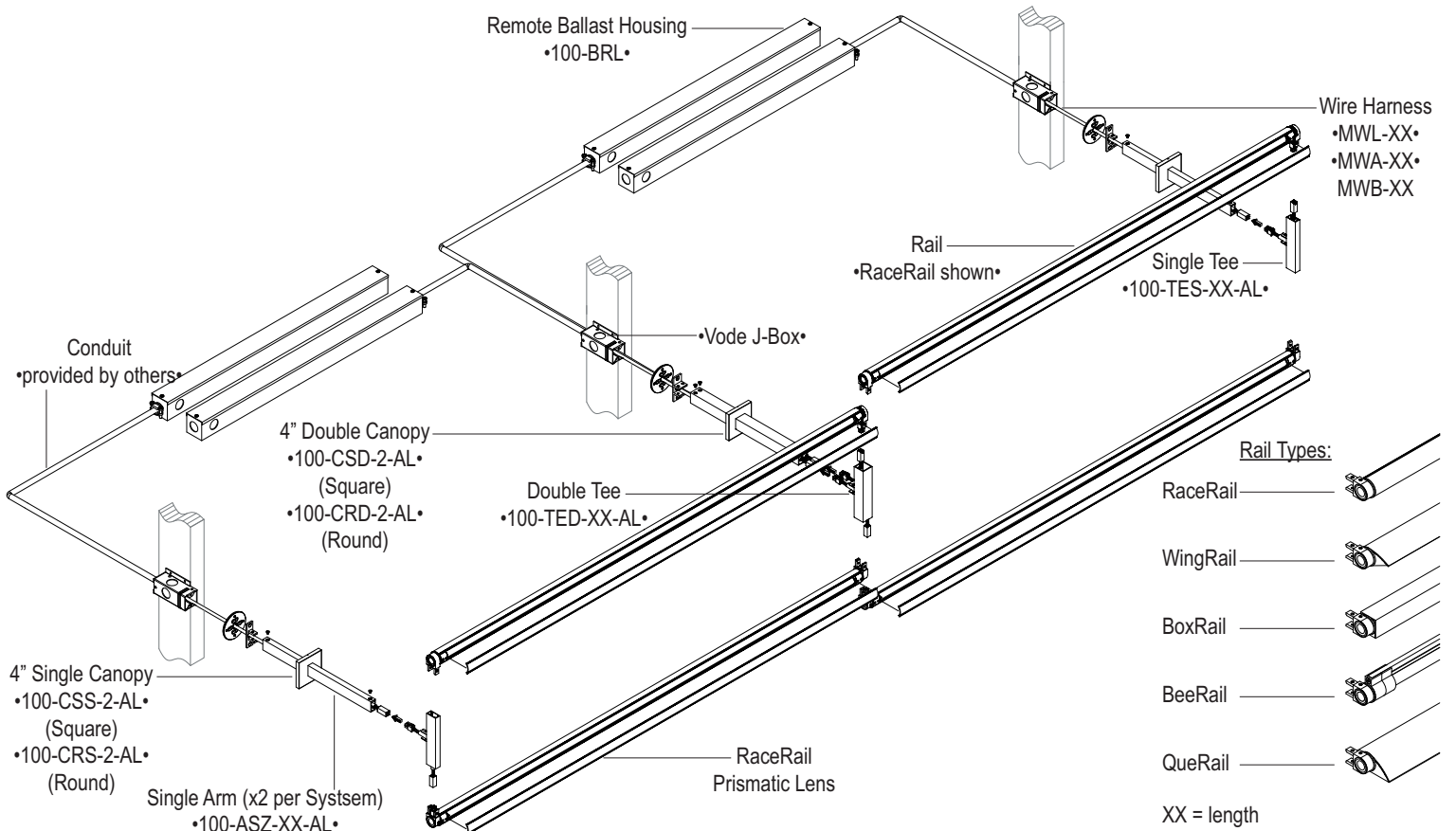

1 Laying out the Vode J-Boxes:

To determine J-Box location and layouts, refer to the layout diagram on page 4. Accurate placement and alignment of J-Box is very important. Once drywall is installed only a small amount of adjustability is possible! Do not expect the studs/joists to be aligned especially on runs over 8 feet, use your laser level!! J-Boxes must be in line, plumb and level! Secure J-Box to structure. Be sure to account for drywall thickness. Front of J-Box should be mounted just shy of finished drywall surface.

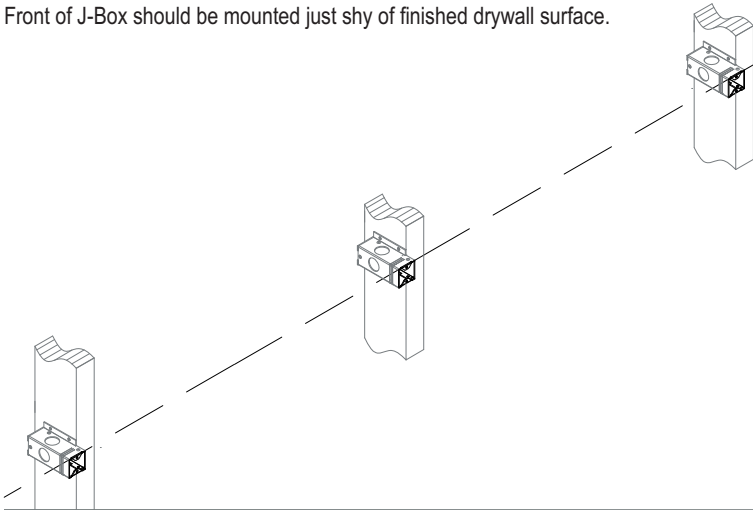

2 Installing Remote Ballast Housing:

Note: Mid-sections take two Power Harness. Mount Remote Ballast Housing to a location that is accessible after installation. Maximum distance from Rail to a standard non-dimming ballast is 14'. Maximum for dimming ballast is 7'. Include Arm length in calculation. Connect J-Box to Remote Ballast Housing with conduit (not provided). Rigid or Flexible conduit may be used depending on local code requirements.

Do not install Vode Wire Harness at this time.
 Do not connect line voltage power at this time.

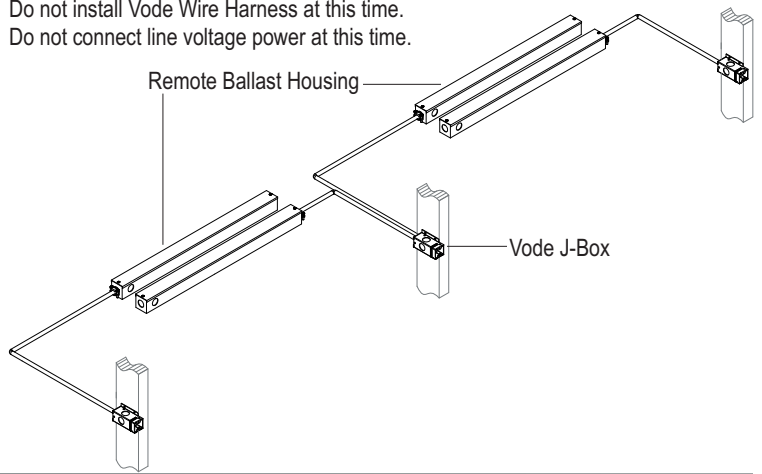

3 Connecting Wire Harness and Ballast:

AFTER drywall has been installed:
 Insert Wire Harness through Mounting Plate & Arm Mounting Bracket as shown. Pull Wire Harness from J-Box to Remote Ballast Housing. Leave 1" plus length of Arm (example; 12" Arm + 1" = 13") hanging out of j-box. Use Vode Wire Harness provided, Vode DOES NOT recommend using installer-supplied wire for ballast to Rail connections. Refer to Wiring Diagram on page 4. Make lamp and line voltage connections to ballast. DO NOT power on System at this time.

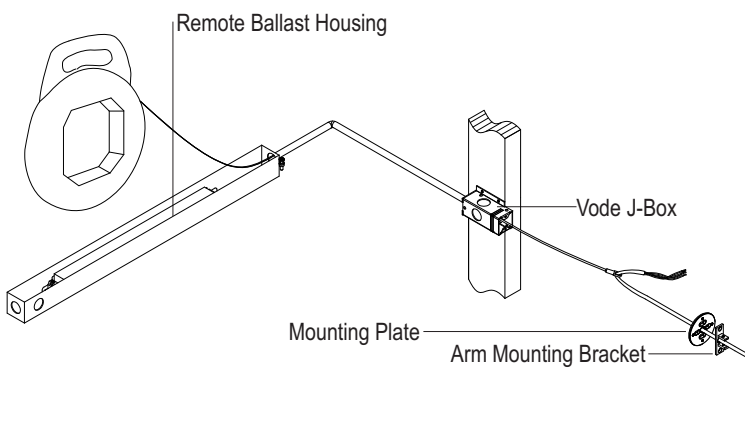

4 Securing Mounting Plate & Arm Mounting Bracket:

Secure Mounting Plate to J-Box & Arm Mounting Bracket to Mounting Plate using screws provided. Plates have very minimum adjustment, double check your center-to-center location as per layout diagram on page 4.

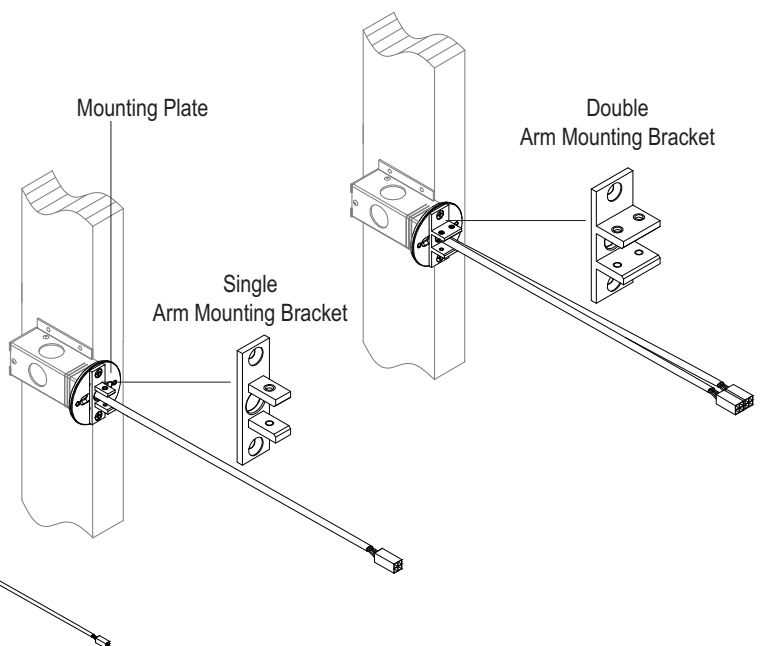

5 Installing the Arms:

Slip Wire Harness through Arm as shown.
 Secure Arm to Arm Mounting Bracket using provided screws.
 Slip Canopy over Arm and snap onto Mounting Plate.

Note:
 Double Arms take two Power Harness.

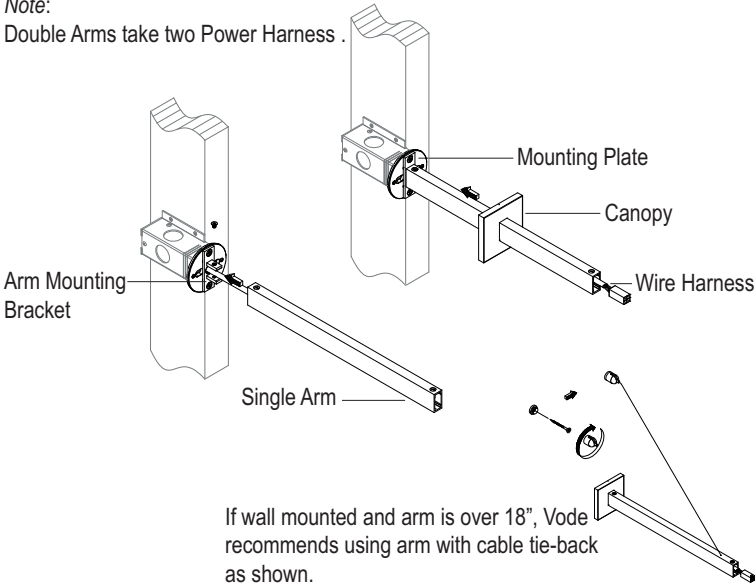

6 Installing Tees:

Before installing Tees, check wiring diagram on page 4 for correct Tee orientation.
 If using WingRail on system, also check WingRail Orientation desired to determine Tee orientation.

Make Wire Harness connections between Arm and Tee as shown.
 Make sure mating connector parts are completely secured.
 Secure Tee to Arm using screws provided.

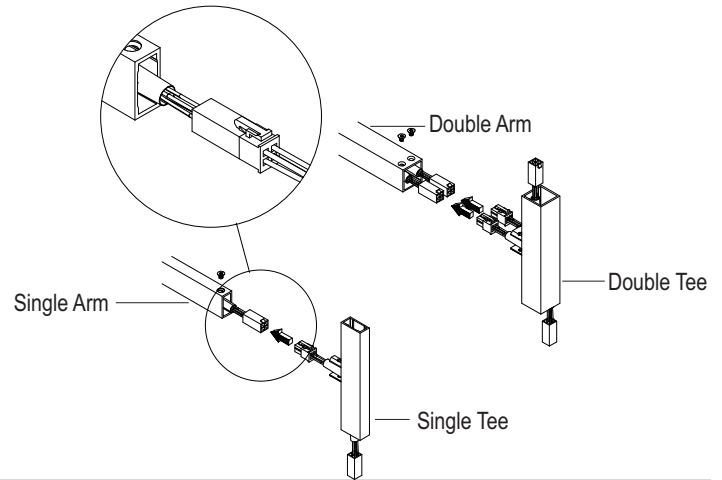

7 Installing Rails:

Snap connector on Tee to mating connector on Rail.
 Make sure mating connector parts are completely secured.
 Secure Rail to Tee using provided screws.

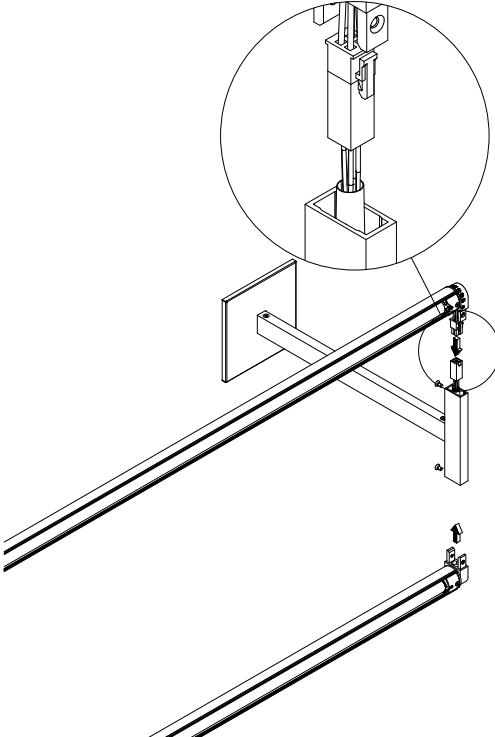

8 Installing Lamps & Adjusting Rails:

IMPORTANT: Use only T5 lamps in correct wattage! See label inside Rail.

Install lamps. For WingRail, BoxRail and RaceRail (shown), turn socket rotor tab to properly position and secure lamp. If lens is applied, install lens.
 Power-on system and let lamps burn in per lamp manufacturers recommendations (usually 50-100 hours).

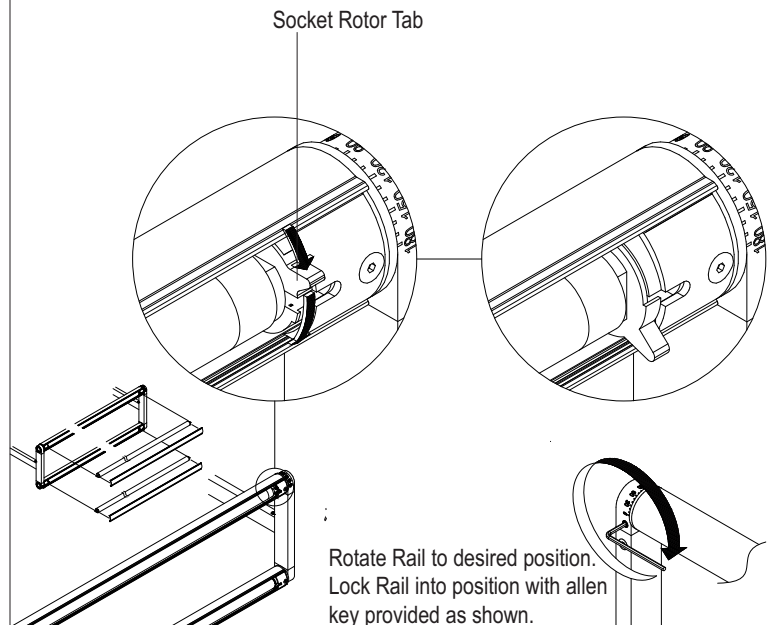

2" Canopy Layout and Rail Lengths

Center to Center Layout for 2" Canopies - 2', 3', 4', and 5' Rails

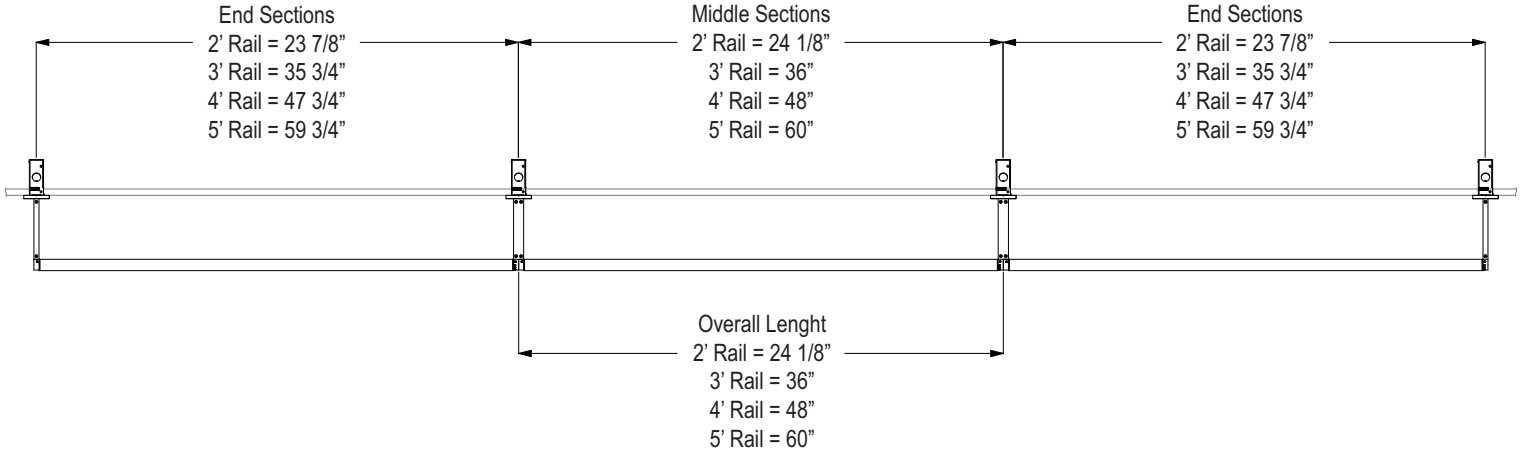

Wiring Diagram for MLR System

1 - lamp wiring for standard non-dimming programmed-start-ballast

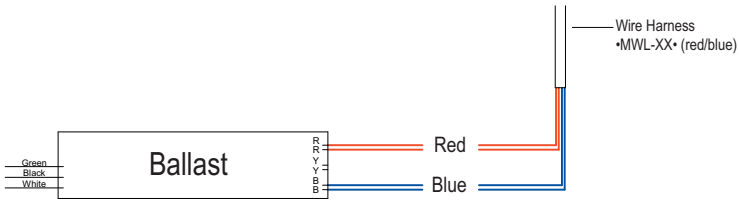

NOTE:
 For dimming and emergency ballast wiring, please contact ballast manufacturer.

IMPORTANT:

Do not exceed maximum allowable distance between ballast and furthest socket. Add Rail length, Half Tee length and Arm-to-Ballast distance in calculation.

Example:
 A+B+C = maximum distance allowed from furthest socket.

Maximum distance from ballast to **furthest** socket:

Non-dimming programmed-start-ballast	14'
Emergency ballast with Non-dimming ballast	10'
Lutron 10% dimming	7'
Lutron 1% dimming	7'
Lutron Eco-System ballast	7'
Emergency ballast with dimming ballast	7'

